

| REVISION RECORD |     |              |        |         |
|-----------------|-----|--------------|--------|---------|
| REV             | ECO | DESCRIPTION  | DRFT   | CHKD    |
| △               |     | ADD PART NO. | Gianni | 4/21/05 |

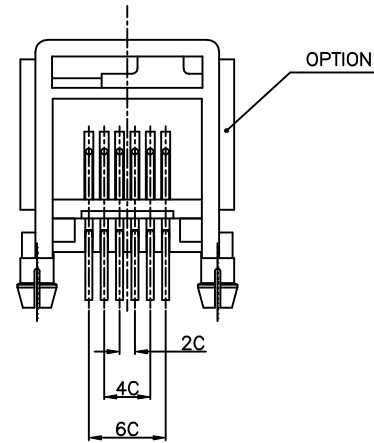
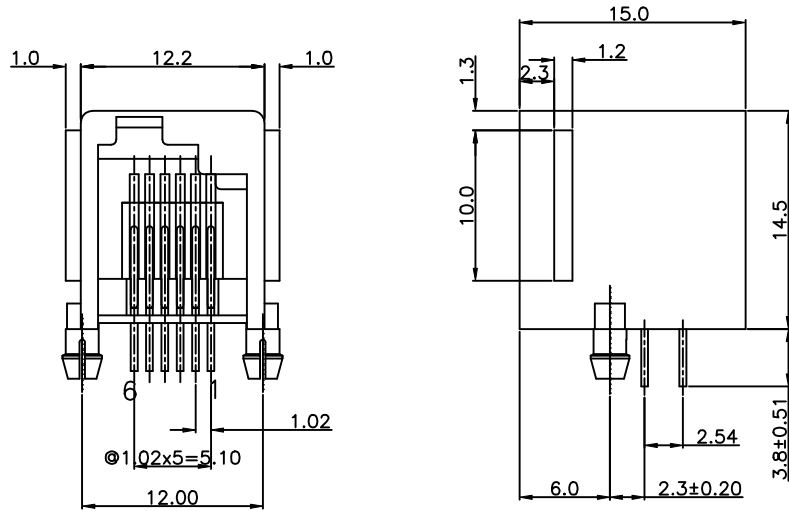

**NOTES:**

ELECTRICAL:

1. VOLTAGE RATING : 125 VAC RMS.
2. CURRENT RATING : 1.5 AMP.
3. CONTACT RESISTANCE : 30 MILLIOHMS MAX.
4. INSULATION RESISTANCE: 1000 MEGOHMS MIN @ 500 VDC.
5. DIELECTRIC STRENGTH : 1000 VAC RMS 60Hz, 1MIN.

MECHANICAL:

1. HOUSING MATERIAL : NYLON+30%.G.F(FR52) UL94V-0.
2. CONTACT MATERIAL : PHOSPHOR BRONZE  $\phi$ 0.46mm.
3. PLATING : GOLD PLATING OVER NICKEL.
4. OPERATING LIFE : 750 CYCLES MIN.
5. PCB RETENTION PRE-SOLDER : 1 LB MIN.
6. PCB RETENTION POST-SOLDER: 10 LBS MIN.

ENVIRONMENTAL:

1. STORAGE : -40°C TO +85°C.
  2. OPERATION: -40°C TO +85°C.
  3. WAVE SOLDERING TEMPERATURE: 255°C~265°C(5~10 SECONDS)
- MATES WITH MODULAR PLUG CONFORMING TO  
FCC PART 68, SUBPART F.  
CUL FILE NO. E163191

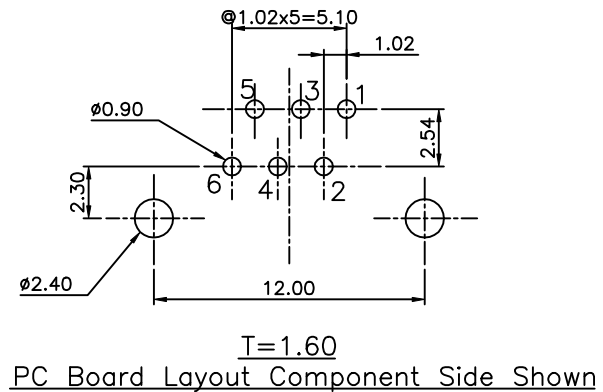

PART NUMBER: E556X-DOLUXX-L

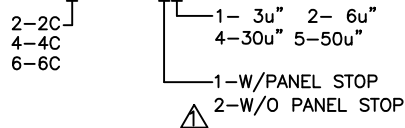

|                        |                            |             |                         |                                |       |
|------------------------|----------------------------|-------------|-------------------------|--------------------------------|-------|
| DETACHED LISTS         | MM (INCH)                  | DFTO JAMY   | DATE 4/07/05            | FULL RISE ELECTRONIC CO., LTD  |       |
|                        | TOLERANCES EXCEPT AS NOTED | CHKDYMAN    | DATE 2005/4/23          |                                |       |
|                        | MM                         | MFO         | DATE                    | TITLE<br>DEC TYPE L/P PCB JACK |       |
|                        | .0 ±0.2                    | APPLVLSAMMY | DATE 2005/4/23          |                                |       |
| .00 ±0.15              | MATERIAL :                 |             | DRAWING NO. GE553A50-LA |                                |       |
| .000 ±0.075            | ANGLES ± 0.5               |             | /PART NO. SEE NOTE      |                                |       |
| THIRD ANGLE PROJECTION | SCALE : 3 : 1              |             | DO NOT SCALE DRAWING    |                                |       |
|                        |                            | QTY :       |                         | SIZE A3                        | REV 1 |
|                        |                            | FINISH :    |                         | SHEET OF                       |       |